

Surge Protection Barrier

P-LB-1.D.1234

- 1-channel
- Plugs directly in to field side of KF modules
- Analog or digital signal inputs
- Surge protection up to 10 kA
- Protects leads 1, 2, 3 and 4 of KF modules
- Uninterruptable operation (auto reset)
- Up to SIL 3 acc. to IEC/EN 61508



Function

This Surge Protection Barrier is designed for use with K-System (KF modules). By simply snapping the barriers into a standard KF module, the modules are safely protected against voltage surges of different origin (e. g. lightning stroke, switching impulse, etc.). This is achieved by diverting the transient current to ground and limiting the signal line voltage to a safe level for the duration of the surge. The end digits of the model designation correspond to the protected terminals of the respective KF module. For additional information, refer to the manual and www.pepperl-fuchs.com.

Note: Surge Protection Barriers must always be connected to a solid and effective ground and be at the same equipotential level as the instrument it is protecting. The ground system must comply with all applicable regulations.

Connection

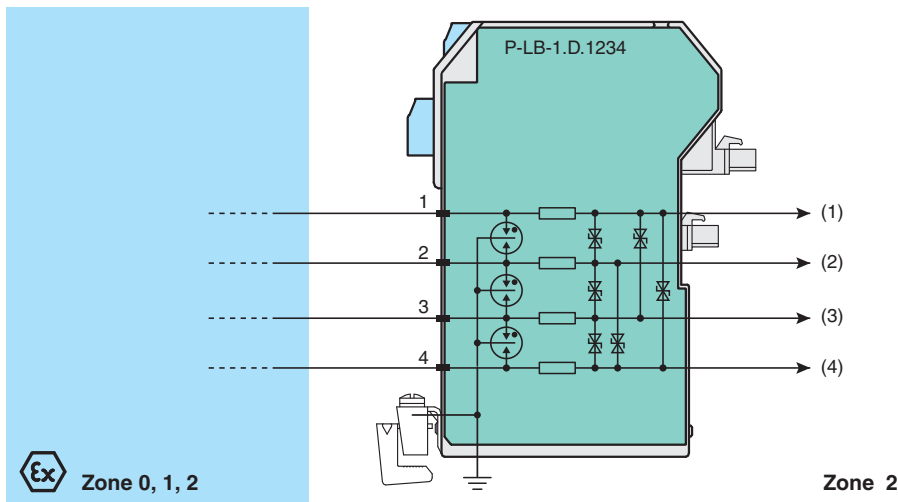

Technical Data

General specifications			
Number of protected signal lines	4		
Functional safety related parameters			
Safety Integrity Level (SIL)	SIL 3		
Signal lines			
Connection	terminals 1, 2, 3, 4		
Rated voltage	U_B	max. 30 V	
Rated current	I_B	max. 250 mA	

Release date: 2022-01-12 Date of issue: 2022-01-12 Filename: 103642_eng.pdf

Refer to "General Notes Relating to Pepperl+Fuchs Product Information".

Pepperl+Fuchs Group
www.pepperl-fuchs.com

USA: +1 330 486 0002
pa-info@us.pepperl-fuchs.com

Germany: +49 621 776 2222
pa-info@de.pepperl-fuchs.com

Singapore: +65 6779 9091
pa-info@sg.pepperl-fuchs.com

PEPPERL+FUCHS

Technical Data

Leakage current		max. 5 μ A
On-state voltage		max. 45 V
Ground insulation		max. 500 V breakdown voltage
Conformity		
Degree of protection		IEC 60529:2001
Ambient conditions		
Ambient temperature		-20 ... 60 °C (-4 ... 140 °F)
Mechanical specifications		
Degree of protection		IP20
Mass		approx. 70 g
Dimensions		20 x 104 x 127 mm (0.8 x 4.1 x 5 inch) (W x H x D)
Mounting		on the KF module
Data for application in connection with hazardous areas		
EU-type examination certificate		PTB 02 ATEX 2044
Marking		Ⓜ II (1)G [Ex ia Ga] IIC
Voltage	U_i	30 V
Current	I_i	250 mA
Internal capacitance	C_i	negligible
Internal inductance	L_i	300 μ H
Maximum leakage current		10 kA (8/20 μ s) per conductor
Nominal response time		
Symmetrical		1 ns
Asymmetric		100 ns
Series resistor		$\leq 0.5 \Omega$ per wire
Bandwidth		≥ 40 kHz
Certificate		PF 16 CERT 3908 X
Marking		Ⓜ II 3G Ex nA IIC T4 Gc
Directive conformity		
Directive 2014/34/EU		EN 60079-0:2012+A11:2013 , EN 60079-11:2012 , EN 60079-15:2010
International approvals		
IECEX approval		
IECEX certificate		IECEX BAS 12.0123
IECEX marking		[Ex ia Ga] IIC, [Ex ia Da] IIIC, [Ex ia Ma] I
General information		
Supplementary information		Observe the certificates, declarations of conformity, instruction manuals, and manuals where applicable. For information see www.pepperl-fuchs.com .

Assembly

Front view

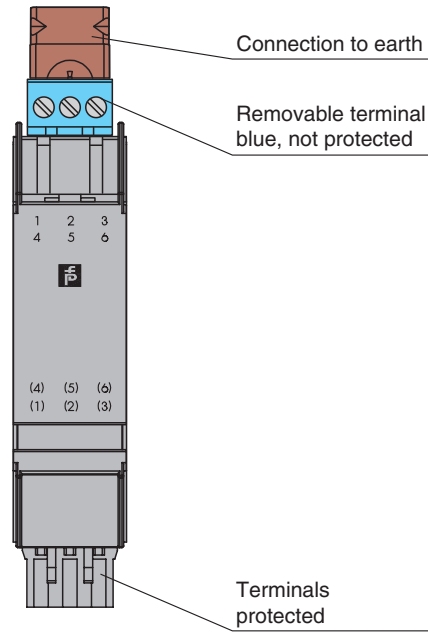

Accessories

ZH-Z.AK16	Connection terminal for grounding rail
ZH-Z.AB/SS	Mounting block for grounding rail
ZH-Z.NLS-Cu3/10	Grounding Rail

Release date: 2022-01-12 Date of issue: 2022-01-12 Filename: 103642_eng.pdf

Refer to "General Notes Relating to Pepperl+Fuchs Product Information".

Pepperl+Fuchs Group
www.pepperl-fuchs.com

USA: +1 330 486 0002
pa-info@us.pepperl-fuchs.com

Germany: +49 621 776 2222
pa-info@de.pepperl-fuchs.com

Singapore: +65 6779 9091
pa-info@sg.pepperl-fuchs.com

pf PEPPERL+FUCHS

Installation

- | | |
|-----------------------|---|
| 1 Connection terminal | ZH-Z.AK16 |
| 2 Mounting block | ZH-Z.AB/SS |
| 3 Spacing roller | when mounting on 35 mm DIN EN 60715 mounting rail:
– installation height 15 mm: spacing roller ZH-Z.AR.85
– installation height 7.5 mm: no spacing roller necessary |
| 4 Grounding rail | ZH-Z.NLS-Cu3/10 |

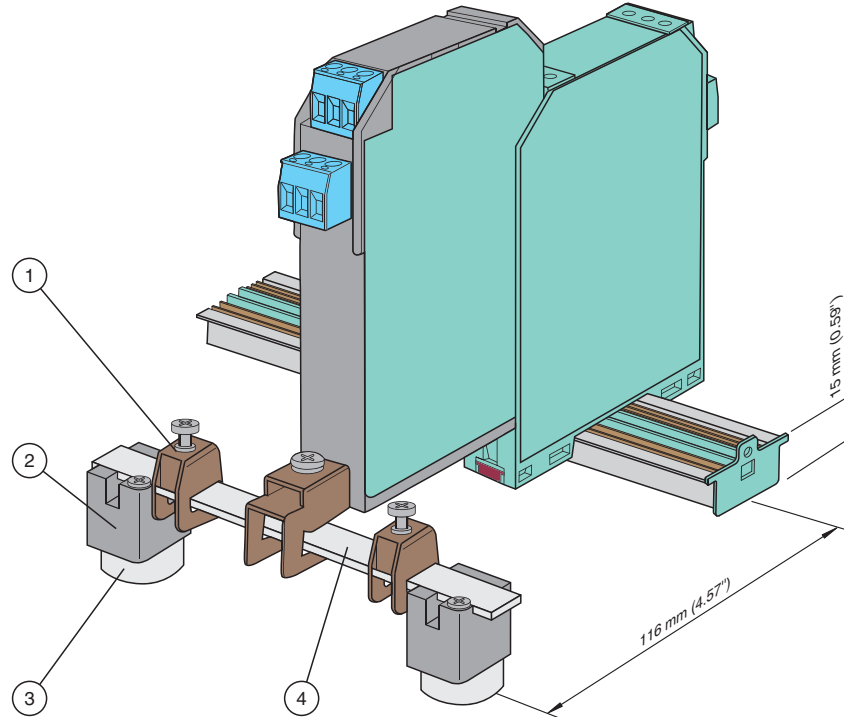

Keep the drilling distance of 116 mm between center mounting rail and center grounding bar.